

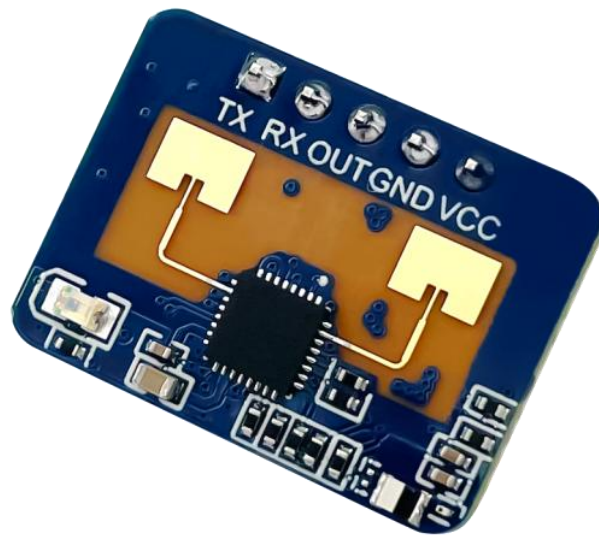

Shenzhen Hi-Link Electronic Co.,Ltd

HLK-LD2410C

**Human presence sensing module
serial communication protocol**



Version: V1.07 Modify date: 2024-8-5

Copyright @Shenzhen Hi-Link Electronic Co.,Ltd

Contents

| | |
|---|-----------|
| 1 Communication interface introduction | 5 |
| 1.1 Pin definition | 5 |
| 1.2 Use and configuration | 6 |
| 1.2.1 Typical application circuits | 6 |
| 1.2.2 The role of configuration parameters | 6 |
| 1.2.3 Visual configuration tool description | 7 |
| 2 Communication protocols | 8 |
| 2.1 Protocol format | 8 |
| 2.1.1 Protocol data format | 8 |
| 2.1.2 Command protocol frame format | 8 |
| 2.2 Send command with ACK | 9 |
| 2.2.1 Enabling configuration commands | 9 |
| 2.2.2 End configuration command | 9 |
| 2.2.3 Maximum distance gate and unoccupied duration parameters configuration command | 10 |
| 2.2.4 Read parameter command | 11 |
| 2.2.5 Enabling engineering mode command | 11 |
| 2.2.6 Close project mode command | 12 |
| 2.2.7 Distance gate sensitivity configuration command | 12 |
| 2.2.8 Read firmware version command | 13 |
| 2.2.9 Set serial port baud rate | 13 |
| 2.2.10 Restore factory settings | 14 |
| 2.2.11 Restart module | 15 |
| 2.2.12 Bluetooth settings | 16 |
| 2.2.13 Get mac address | 16 |
| 2.2.14 Obtaining bluetooth permissions | 16 |
| 2.2.15 Setting Bluetooth password | 17 |

2.2.16 Distance resolution setting17

2.2.17 Query distance resolution setting 18

2.2.18 Auxiliary control function settings 17

2.2.19 Query auxiliary control function configuration 180

**2.2.20 Start performing background noise detection and automatic
sensitivity configuration170**

2.2.21 Query the execution status of bottom noise detection 218

2.3 Radar data output protocol21

2.3.1 Reported data frame format 22

2.3.2 Target data composition 22

2.4 Radar command configuration method24

2.4.1 Radar command configuration steps 24

3 Revision records 26

4 Technical support and contact information 27

Chart Index

| | | |
|-----------------|---|-----------|
| Table 1 | Pin definition table | 5 |
| Table 2 | Send command protocol frame format | 9 |
| Table 3 | Data format in the sending frame | 9 |
| Table 4 | ACK command protocol frame format | 9 |
| Table 5 | ACK intra-frame data format | 9 |
| Table 6 | Serial port baud rate selection | 14 |
| Table 7 | Factory default configuration values | 15 |
| Table 8 | Distance resolution selection | 18 |
| Table 9 | Command values for auxiliary control function settings | 18 |
| Table 10 | Reported data frame format | 22 |
| Table 11 | Intra-frame data frame format | 22 |
| Table 12 | Data type description | 22 |
| Table 13 | Target basic information data composition | 22 |
| Table 14 | Target state value description | 23 |
| Table 15 | Engineering model target data composition | 23 |
| Figure 1 | Module pin definition diagram | 5 |
| Figure 2 | Radar command configuration process | 25 |

1 Communication interface introduction

1.1 Pin definition

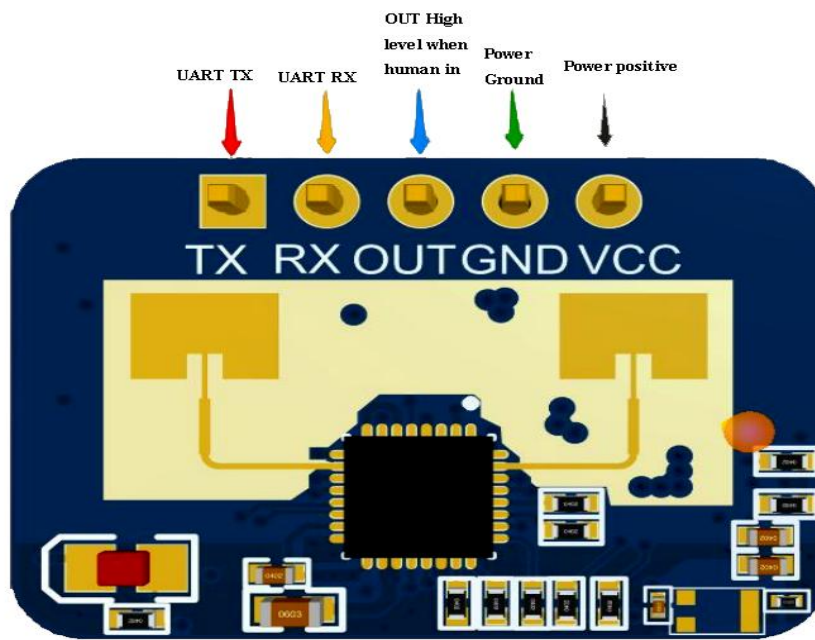

Figure 1 Module pin definition diagram

| Pin | Symbol | Name | Function |
|-----|---------|---------------------|---|
| 1 | UART_Tx | UART Tx | UART Tx pin |
| 2 | UART_Rx | UART Rx | UART Rx pin |
| 3 | OUT | Target state output | Human presence detected: output high level No human presence: output low level |
| 4 | GND | Power Ground | Power Ground |
| 5 | VCC | Power input | Power input 5V |

Table 1 Pin definition table

1.2 Use and configuration

1.2.1 Typical application circuits

LD2410C module directly through an IO pin output the detected target state (someone high, no one low), but also through the serial port in accordance with the prescribed protocol for the output of the detection results data, the serial output data contains the target state and distance auxiliary information, etc., the user can be used flexibly according to specific application scenarios.

The module power supply voltage is 5V and the power supply capacity of the input power supply is required to be greater than 200mA.

The module IO output level is 3.3 V. The default baud rate of the serial port is 256000, with 1 stop bit and no parity bit.

1.2.2 The role of configuration parameters

Users can modify the configuration parameters to the module through the serial port of LD2410C to adapt to different application requirements.

The configurable radar detection parameters include the following :

- **The farthest detection distance**

Set the farthest detectable distance, only human targets that appear within this farthest distance will be detected and output results.

Set in units of distance gates, with a maximum of 8 distance gates and configurable distance resolution (0.2m or 0.75m per distance gate).

Including the farthest distance door for motion detection and the farthest distance door for stationary detection, the range can be set from 1 to 8. For example, if the farthest distance door is set to 2 and the distance resolution is 0.75m, only the presence of a human body within 1.5m will be effectively detected and the result output.

- **Sensitivity**

The presence of a target is determined when the detected target energy value (range 0 to 100) is greater than the sensitivity value, otherwise it is ignored.

Sensitivity value can be set in the range of 0 to 100. Each distance gate can be set independently of the sensitivity, that is, the detection of different distances within the

range of precise adjustment, local precision detection or filtering of specific areas of interference sources.

In addition if the sensitivity of a distance gate is set to 100, the effect of not identifying the target under this distance gate can be achieved. For example, the sensitivity of distance gate 3 and distance gate 4 is set to 20, and the sensitivity of all other distance gates is set to 100, then only the human body within 2.25 to 3.75m of the distance module can be achieved to detect.

● **no-one duration**

Radar in the output from occupied to unoccupied results, will continue to report a period of time on the occupied, if the radar test range in this time period continued unoccupied, the radar reported unoccupied; if the radar detects someone in this time period, then refreshed this time, unit seconds. Equivalent to no one delay time, after the person left, keep no one more than this duration before the output status for no one.

1.2.3 Visual configuration tool description

In order to facilitate users to quickly and efficiently test and configure the module, the PC terminal configuration tool is provided. Users can use this tool software to connect to the serial port of the module, read and configure the parameters of the module, and also receive the detection result data reported by the module, and make real-time visualization display, which is greatly convenient for users.

Usage of the Uplink tool:

1. properly connect the module serial port with the USB to serial port tool.
2. select the corresponding serial port number in the upper computer tool, set the baud rate 256000, select the engineering mode and click connect the device.
3. after successful connection, click the start button, the right graphical interface will display the detection results and data.
4. after connection, when the start button is not clicked, or click stop after starting, the mode parameter information can be read or set.

Note: Parameters cannot be read and configured after clicking Start, and can only be configured after stopping.

The interface and common functions of the OP tool are shown below :

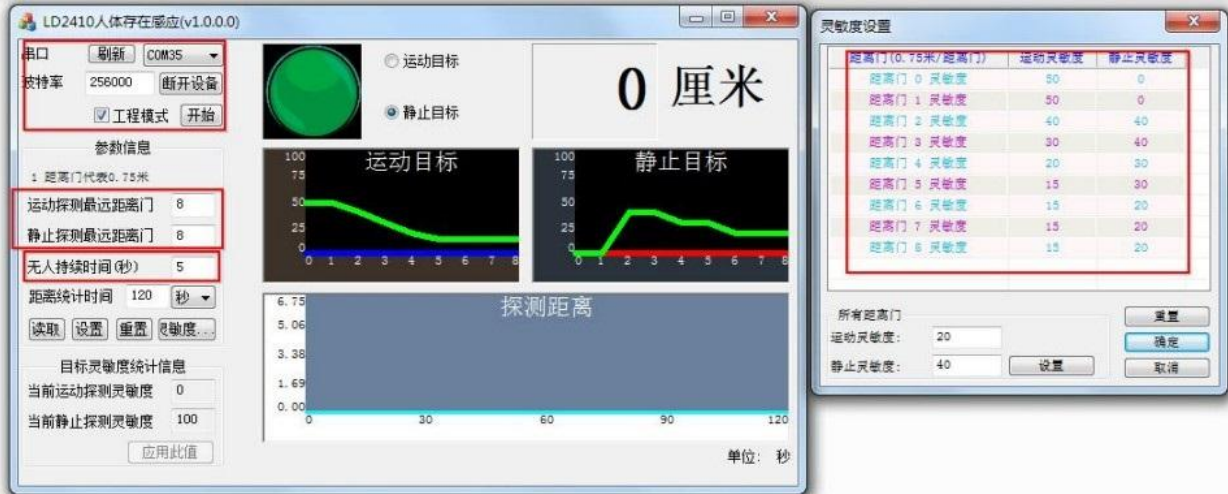

The ball is the target status output indication: **red** means there is a moving target; **purple** means there is a stationary target; **green** means no one.

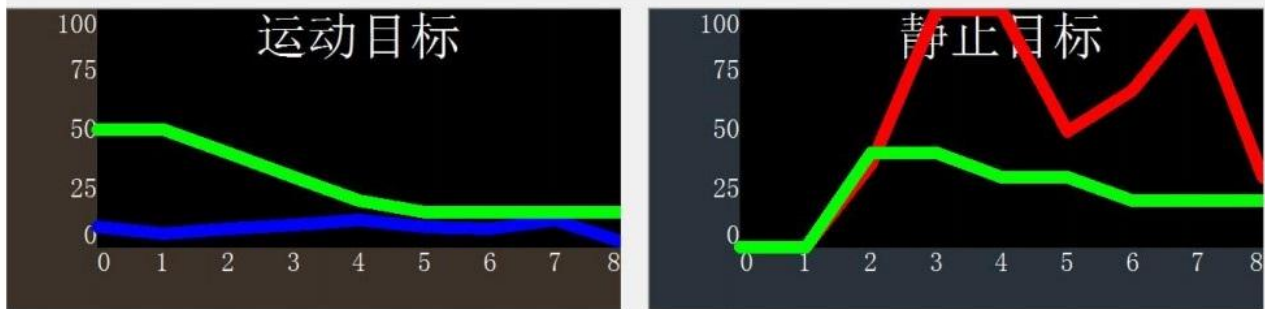

Green line: the set sensitivity

Blue line: moving target energy value on each distance gate

Red line: static target energy value on each range gate

2 Communication protocols

The LD2410C communicates with the outside world through a serial port (TTL level). Data output and parameter configuration commands of the radar are carried out under this protocol. The default baud rate of the radar serial port is 256000, 1 stop bit, no parity bit.

2.1 Protocol format

2.1.1 Protocol data format

The LD2410C uses small-end format for serial data communication, and all data in the following tables are in hexadecimal.

2.1.2 Command protocol frame format

The format of the protocol-defined radar configuration commands and ACK commands are shown in Table 1 to Table 4.

Table 2 Send command protocol frame format

| Frame header | Intra-frame data length | Intra-frame data | End of frame |
|--------------|-------------------------|------------------|--------------|
| FD FC FB FA | 2 bytes | See Table 3 | 04 03 02 01 |

Table 3 Data format in the sending frame

| | |
|------------------------|-------------------------|
| Command word (2 bytes) | Command value (N bytes) |
|------------------------|-------------------------|

Table 4 ACK command protocol frame format

| Frame header | Intra-frame data length | Intra-frame data | End of frame |
|--------------|-------------------------|------------------|--------------|
| FD FC FB FA | 2 bytes | See Table 5 | 04 03 02 01 |

Table 5 ACK intra-frame data format

| | |
|--------------------------------------|------------------------|
| Send command word 0x0100 (2 bytes) | Return value (N bytes) |
|--------------------------------------|------------------------|

2.2 Send command with ACK

2.2.1 Enabling configuration commands

Any other commands issued to the radar must be executed after this command is issued, otherwise they are invalid.

Command word: 0x00FF

Command value: 0x0001

Return value: 2 bytes ACK status (0 success, 1 failure) + 2 bytes protocol version (0x0001) + 2 bytes buffer size (0x0040)

Send data:

| | | | | |
|--------------------|--------------|--------------|--------------|--------------------|
| FD FC FB FA | 04 00 | FF 00 | 01 00 | 04 03 02 01 |
|--------------------|--------------|--------------|--------------|--------------------|

Radar ACK (success):

| | | | | | | |
|--------------------|--------------|--------------|--------------|--------------|--------------|--------------------|
| FD FC FB FA | 08 00 | FF 01 | 00 00 | 01 00 | 40 00 | 04 03 02 01 |
|--------------------|--------------|--------------|--------------|--------------|--------------|--------------------|

2.2.2 End configuration command

End the configuration command and the radar resumes working mode after execution. If you need to issue other commands again, you need to send the enable configuration command first.

Command word: 0x00FE

Command value: None

Return value: 2-byte ACK status (0 success, 1 failure)

Send data:

| | | | |
|-------------|-------|-------|-------------|
| FD FC FB FA | 02 00 | FE 00 | 04 03 02 01 |
|-------------|-------|-------|-------------|

Radar ACK (success):

| | | | | |
|-------------|-------|-------|-------|-------------|
| FD FC FB FA | 04 00 | FE 01 | 00 00 | 04 03 02 01 |
|-------------|-------|-------|-------|-------------|

2.2.3 Maximum distance gate and unoccupied duration parameters configuration command

This command sets the radar maximum detection distance gate (motion & stationary) (configuration range 2~8), and the unmanned duration parameter (configuration range 0~65535 seconds). Please refer to the specific parameter word Table 5- 5. This configuration value is not lost when power is dropped.

Command word: 0x0060

Command value: 2-byte maximum motion distance gate word + 4-byte maximum motion distance gate parameter + 2-byte maximum standstill distance gate word + 4-byte maximum standstill distance gate parameter + 2-byte unoccupied duration word + 4-byte unoccupied duration parameter

Return value: 2-byte ACK status (0 success, 1 failure)

0x0060 protocol parameter word

| Parameter name | Parameter word |
|--------------------------------|----------------|
| Maximum movement distance door | 0x0000 |
| Maximum resting distance door | 0x0001 |
| No one duration | 0x0002 |

Send data: maximum distance door 8 (motion & stationary), no one duration 5 seconds

| | | | | | | | | | |
|-------------|-------|-------|-------|-------------|-------|-------------|-------|-------------|-------------|
| FD FC FB FA | 14 00 | 60 00 | 00 00 | 08 00 00 00 | 01 00 | 08 00 00 00 | 02 00 | 05 00 00 00 | 04 03 02 01 |
|-------------|-------|-------|-------|-------------|-------|-------------|-------|-------------|-------------|

Radar ACK (success):

| | | | | |
|-------------|-------|-------|-------|-------------|
| FD FC FB FA | 04 00 | 60 01 | 00 00 | 04 03 02 01 |
|-------------|-------|-------|-------|-------------|

2.2.4 Read parameter command

This command allows you to read the current configuration parameters of the radar.

Command word: 0x0061

Command value: None

Return value: 2 bytes ACK status (0 success, 1 failure) + header (0xAA) + max distance gate N (0x08) + configure max motion distance gate + configure max rest distance gate + distance gate 0 motion sensitivity (1 byte) + ... + distance gate N motion sensitivity (1 byte) + distance gate 0 rest sensitivity 1 byte) + ... + distance gate N stationary sensitivity (1 byte) + unoccupied duration (2 bytes)

Send data:

| | | | |
|-------------|-------|-------|-------------|
| FD FC FB FA | 02 00 | 61 00 | 04 03 02 01 |
|-------------|-------|-------|-------------|

Radar ACK: (success, maximum distance gate 8, configured motion distance gate 8, stationary distance gate 8, 0~8 motion sensitivity 20, 0~8 stationary sensitivity 25, unoccupied duration 5 seconds)

| Byte 1~4 | | Byte 5, 6 | | Byte 7, 8 | | Byte 9, 10 | Byte 11 | Byte 12 | Byte 13 | Byte 14 | Byte 15 | Byte 16 | Byte 17 | Byte 18 |
|-------------|---------|-------------|--|-------------|---------|------------|---------|---------|---------|---------|---------|---------|---------|---------|
| FD FC FB FA | | 1C 00 | | 61 01 | | 00 00 | AA | 08 | 08 | 08 | 14 | 14 | 14 | 14 |
| Byte 19 | Byte 20 | Byte 21 | | Byte 22 | Byte 23 | Byte 24 | Byte 25 | Byte 26 | Byte 27 | Byte 28 | Byte 29 | Byte 30 | | |
| 14 | 14 | 14 | | 14 | 14 | 19 | 19 | 19 | 19 | 19 | 19 | 19 | | |
| Byte 31 | Byte 32 | Byte 33, 34 | | Byte 35~38 | | | | | | | | | | |
| 19 | 19 | 05 00 | | 04 03 02 01 | | | | | | | | | | |

2.2.5 Enabling engineering mode command

This command opens the radar engineering mode. When the engineering mode is turned on, each distance gate energy value will be added to the radar report data, please refer to [2.3.2 Target Data Composition](#) for detailed format. Engineering mode is off by default after the module is powered on, this configuration value is lost when power is lost.

Command word: 0x0062

Command value: None

Return value: 2-byte ACK status (0 success, 1 failure)

Send data:

| | | | |
|-------------|-------|-------|-------------|
| FD FC FB FA | 02 00 | 62 00 | 04 03 02 01 |
|-------------|-------|-------|-------------|

Radar ACK (success):

| | | | | |
|-------------|-------|-------|-------|-------------|
| FD FC FB FA | 04 00 | 62 01 | 00 00 | 04 03 02 01 |
|-------------|-------|-------|-------|-------------|

2.2.6 Close project mode command

This command turns off the radar engineering mode. After it is turned off, please refer to [2.3.2 Target Data Composition](#) for the format of radar report data.

Command word: 0x0063

Command value: None

Return value: 2-byte ACK status (0 success, 1 failure)

Send data:

| | | | |
|-------------|-------|-------|-------------|
| FD FC FB FA | 02 00 | 63 00 | 04 03 02 01 |
|-------------|-------|-------|-------------|

Radar ACK (success):

| | | | | |
|-------------|-------|-------|-------|-------------|
| FD FC FB FA | 04 00 | 63 01 | 00 00 | 04 03 02 01 |
|-------------|-------|-------|-------|-------------|

2.2.7 Distance gate sensitivity configuration command

This command configures the sensitivity of the distance gate, and the configured value is not lost when power is dropped. It supports both configuring each distance gate individually and configuring all distance gates to a uniform value at the same time. If setting all distance gates sensitivity to the same value at the same time, the distance gate value needs to be set to 0xFFFF.

Command word: 0x0064

Command value: 2-byte distance gate word + 4-byte distance gate value + 2-byte motion sensitivity word + 4-byte motion sensitivity value + 2-byte standstill sensitivity word + 4-byte standstill sensitivity value

Return value: 2-byte ACK status (0 success, 1 failure)

0x0064 protocol parameter word

| Parameter name | Parameter word |
|----------------|----------------|
| Distance door | 0x0000 |

| | |
|---------------------------|--------|
| Movement sensitivity word | 0x0001 |
| Static Sensitivity Word | 0x0002 |

Send data: configured distance from the door 3 motion sensitivity 40, stationary sensitivity 40

| | | | | | | | | | |
|-------------|-------|-------|-------|-------------|-------|-------------|-------|-------------|-------------|
| FD FC FB FA | 14 00 | 64 00 | 00 00 | 03 00 00 00 | 01 00 | 28 00 00 00 | 02 00 | 28 00 00 00 | 04 03 02 01 |
|-------------|-------|-------|-------|-------------|-------|-------------|-------|-------------|-------------|

Radar ACK (success):

| | | | | |
|-------------|-------|-------|-------|-------------|
| FD FC FB FA | 04 00 | 64 01 | 00 00 | 04 03 02 01 |
|-------------|-------|-------|-------|-------------|

Send data: Configure motion sensitivity 40 for all distance doors, rest sensitivity 40

| | | | | | | | | | |
|-------------|-------|-------|-------|-------------|-------|-------------|-------|-------------|-------------|
| FD FC FB FA | 14 00 | 64 00 | 00 00 | FF FF 00 00 | 01 00 | 28 00 00 00 | 02 00 | 28 00 00 00 | 04 03 02 01 |
|-------------|-------|-------|-------|-------------|-------|-------------|-------|-------------|-------------|

Radar ACK (success):

| | | | | |
|-------------|-------|-------|-------|-------------|
| FD FC FB FA | 04 00 | 64 01 | 00 00 | 04 03 02 01 |
|-------------|-------|-------|-------|-------------|

2.2.8 Read firmware version command

This command reads the radar firmware version information.

Command word: 0x00A0

Command value: None

Return value: 2 bytes ACK status (0 success, 1 failure) + 2 bytes firmware type (0x0001) + 2 bytes major version number + 4 bytes minor version number

Send data:

| | | | |
|-------------|-------|-------|-------------|
| FD FC FB FA | 02 00 | A0 00 | 04 03 02 01 |
|-------------|-------|-------|-------------|

Radar ACK (success):

| | | | | | | |
|-------------|-------|-------|-------|-------|-------------|-------------|
| FD FC FB FA | 0C 00 | 00 00 | 00 01 | 07 01 | 16 15 09 22 | 04 03 02 01 |
|-------------|-------|-------|-------|-------|-------------|-------------|

The corresponding version number is V1.02.22062416

2.2.9 Set serial port baud rate

This command is used to set the baud rate of the serial port of the module. The configured value is not lost when power is lost, and the configured value takes effect after restarting the module.

Command word: 0x00A1

Command value: 2-byte baud rate selection index

Return value: 2-byte ACK status (0 success, 1 failure)

Table 6 Serial port baud rate selection

| Baud rate selection index value | Baud rate |
|---------------------------------|-----------|
| 0x0001 | 9600 |
| 0x0002 | 19200 |
| 0x0003 | 38400 |
| 0x0004 | 57600 |
| 0x0005 | 115200 |
| 0x0006 | 230400 |
| 0x0007 | 256000 |
| 0x0008 | 460800 |

The factory default value is 0x0007, which is 256000

Send data:

| | | | | |
|--------------------|--------------|--------------|--------------|--------------------|
| FD FC FB FA | 04 00 | A1 00 | 07 00 | 04 03 02 01 |
|--------------------|--------------|--------------|--------------|--------------------|

Radars ACK (success):

| | | | | |
|--------------------|--------------|--------------|--------------|--------------------|
| FD FC FB FA | 04 00 | A1 01 | 00 00 | 04 03 02 01 |
|--------------------|--------------|--------------|--------------|--------------------|

2.2.10 Restore factory settings

This command is used to restore all the configuration values to their non-factory values, which take effect after rebooting the module.

Command word: 0x00A2

Command value: None

Return value: 2-byte ACK status (0 success, 1 failure)

Send data:

| | | | |
|--------------------|--------------|--------------|--------------------|
| FD FC FB FA | 02 00 | A2 00 | 04 03 02 01 |
|--------------------|--------------|--------------|--------------------|

Radars ACK (success):

| | | | | |
|--------------------|--------------|--------------|--------------|--------------------|
| FD FC FB FA | 04 00 | A2 01 | 00 00 | 04 03 02 01 |
|--------------------|--------------|--------------|--------------|--------------------|

The factory default configuration values are as follows:

Table 7 Factory default configuration values

| Configuration items | Default value |
|--------------------------------|---------------|
| Maximum movement distance door | 8 |
| Maximum resting distance door | 8 |
| No one duration | 5 |
| Serial port baud rate | 256000 |
| Distance resolution | 0.75m |

| Configuration items | Default value | Configuration items | Default value |
|---------------------------------------|---------------|---------------------------------------|-----------------|
| Motion sensitivity of distance gate 0 | 50 | Static sensitivity of distance gate 0 | -(not settable) |
| Motion sensitivity of distance gate 1 | 50 | Static sensitivity of distance gate 1 | -(not settable) |
| Motion sensitivity of distance gate 2 | 40 | Static sensitivity of distance gate 2 | 40 |
| Motion sensitivity of distance gate 3 | 30 | Static sensitivity of distance gate 3 | 40 |
| Motion sensitivity of distance gate 4 | 20 | Static sensitivity of distance gate 4 | 30 |
| Motion sensitivity of distance gate 5 | 15 | Static sensitivity of distance gate 5 | 30 |
| Motion sensitivity of distance gate 6 | 15 | Static sensitivity of distance gate 6 | 20 |
| Motion sensitivity of distance gate 7 | 15 | Static sensitivity of distance gate 7 | 20 |
| Motion sensitivity of distance gate 8 | 15 | Static sensitivity of distance gate 8 | 20 |

2.2.11 Restart module

The module receives this command and will automatically restart after the answer is sent.

Command word: 0x00A3

Command value: None

Return value: 2-byte ACK status (0 success, 1 failure)

Send data:

| | | | |
|--------------------|--------------|--------------|--------------------|
| FD FC FB FA | 02 00 | A3 00 | 04 03 02 01 |
|--------------------|--------------|--------------|--------------------|

Radar ACK (success):

| | | | | |
|--------------------|--------------|--------------|--------------|--------------------|
| FD FC FB FA | 04 00 | A3 01 | 00 00 | 04 03 02 01 |
|--------------------|--------------|--------------|--------------|--------------------|

2.2.12 Bluetooth settings

This command is used to control the Bluetooth on or off, the Bluetooth function of the module is on by default.

After receiving this command, a reboot is required for the function to take effect.

Command word: 0x00A4

Command value: 0x0100 Turn on bluetooth 0x0000 Turn off bluetooth

Return value: 2-byte ACK status (0 success, 1 failure)

Send data: (Turn on bluetooth)

| | | | | |
|--------------------|--------------|--------------|--------------|--------------------|
| FD FC FB FA | 04 00 | A4 00 | 01 00 | 04 03 02 01 |
|--------------------|--------------|--------------|--------------|--------------------|

Radar ACK (success):

| | | | | |
|--------------------|--------------|--------------|--------------|--------------------|
| FD FC FB FA | 04 00 | A4 01 | 00 00 | 04 03 02 01 |
|--------------------|--------------|--------------|--------------|--------------------|

2.2.13 Get mac address

This command is used to query the MAC address.

Command word: 0x00A5

Command value: 0x0001

Return value: 2-byte ACK status (0 success, 1 failure) + 1 byte fixed type (0x00) + 3 bytes MAC address (address is in big terminal order)

Send data:

| | | | | |
|--------------------|--------------|--------------|--------------|--------------------|
| FD FC FB FA | 04 00 | A5 00 | 01 00 | 04 03 02 01 |
|--------------------|--------------|--------------|--------------|--------------------|

Radar ACK (success):

| | | | | | | | |
|--------------------|--------------|--------------|--------------|--------------|--------------|--------------|--------------------|
| FD FC FB FA | 0A 00 | A5 01 | 00 00 | 8F 27 | 2E B8 | 0F 65 | 04 03 02 01 |
|--------------------|--------------|--------------|--------------|--------------|--------------|--------------|--------------------|

The mac address queried is: 8F 27 2E B8 0F 65

2.2.14 Obtaining bluetooth permissions

This command is used to get the Bluetooth permission, and you can use the APP to get the device information and debugging parameters through Bluetooth after successful acquisition.

Command word: 0x00A8

Command value: 6 bytes of password value (every 2 bytes in small end order)

Return value: 2-byte ACK status (0 success, 1 failure)

The default password is "HiLink", then the corresponding value is 0x4869 (Hi) 0x4c69 (Li) 0x6e6b (nk).

Send data:

| | | | | | | | |
|-------------|-------|-------|-------|-------|-------|-------|-------------|
| FD FC FB FA | 08 00 | A8 00 | 48 69 | 4c 69 | 6e 6b | 48 69 | 04 03 02 01 |
|-------------|-------|-------|-------|-------|-------|-------|-------------|

Radar ACK (success):

| | | | | |
|-------------|-------|-------|-------|-------------|
| FD FC FB FA | 04 00 | A8 01 | 00 00 | 04 03 02 01 |
|-------------|-------|-------|-------|-------------|

Note: This response only answers to Bluetooth, not to the serial port.

2.2.15 Setting Bluetooth password

This command is used to set the password for Bluetooth control.

Command word: 0x00A9

Command value: 6 bytes of password value (each byte is in small end order)

Return value: 2-byte ACK status (0 success, 1 failure)

Send data:

| | | | | | | | |
|-------------|-------|-------|-------|-------|-------|-------|-------------|
| FD FC FB FA | 08 00 | A9 00 | 48 69 | 4c 69 | 6e 6b | 48 69 | 04 03 02 01 |
|-------------|-------|-------|-------|-------|-------|-------|-------------|

Radar ACK (success):

| | | | | |
|-------------|-------|-------|-------|-------------|
| FD FC FB FA | 04 00 | A9 01 | 00 00 | 04 03 02 01 |
|-------------|-------|-------|-------|-------------|

2.2.16 Distance resolution setting

Set the distance resolution of the module, that is how far away each distance gate represents, the configuration value is not lost when power is lost, and the configuration value takes effect after restarting the module.

Can be configured to 0.75m or 0.2m per distance gate, the maximum number of distance gates supported are 8.

Command word: 0x00AA

Command value: 2-byte distance resolution selection index

Return value: 2-byte ACK status (0 success, 1 failure)

Table 8 Distance resolution selection

| Distance resolution selection index value | Distance resolution (distance represented by each distance gate) |
|---|--|
| 0x0000 | 0.75m |
| 0x0001 | 0.2m |

Factory default value is 0x0001, which is 0.75m.

Send data:

| | | | | |
|--------------------|--------------|--------------|--------------|--------------------|
| FD FC FB FA | 04 00 | AA 00 | 01 00 | 04 03 02 01 |
|--------------------|--------------|--------------|--------------|--------------------|

Radar ACK (success):

| | | | | |
|--------------------|--------------|--------------|--------------|--------------------|
| FD FC FB FA | 04 00 | A1 01 | 00 00 | 04 03 02 01 |
|--------------------|--------------|--------------|--------------|--------------------|

2.2.17 Query distance resolution setting

Query the module's current distance resolution setting, i.e. how far away each distance gate represents.

Command word: 0x00AB

Command value: None

Return value: 2-byte ACK status (0 success, 1 failure) + 2-byte distance resolution selection index

Return value definition is the same as **Table 8 Distance resolution selection**

Send data:

| | | | |
|--------------------|--------------|--------------|--------------------|
| FD FC FB FA | 02 00 | AB 00 | 04 03 02 01 |
|--------------------|--------------|--------------|--------------------|

Radar ACK (success):

| | | | | | |
|--------------------|--------------|--------------|--------------|--------------|--------------------|
| FD FC FB FA | 06 00 | AB 01 | 00 00 | 01 00 | 04 03 02 01 |
|--------------------|--------------|--------------|--------------|--------------|--------------------|

Represents the currently set distance resolution of 0.2m.

2.2.18 Query distance resolution setting

This module comes with a photo diode that can be used to detect the output light sensing value (please refer to Table 15 for the composition of engineering mode target data). Users can also configure the light sensing auxiliary control function to be turned on;

Activate the light sensing auxiliary control function, and the output of the OUT pin

is simultaneously affected by the radar detection results and the light sensing control logic:

The OUT pin output changes from unmanned to manned, and it needs to meet the following conditions: the radar detects the presence of a person and the light sensing auxiliary control logic condition is met;

The OUT pin output changes from manned to unmanned, and it needs to meet the following requirements: radar detects unmanned;

The light sensing control logic can choose to detect that the light sensing value is less than the set light sensing threshold, or detect that the light sensing value is greater than the set light sensing threshold;

The default output level of OUT pin can also be configured;

Command word: 0x00AD

Command value: 4-byte configuration value

Return value: 2-byte ACK status (0 successful, 1 failed)

Table 9 Command values for auxiliary control function settings

| The first byte | Illustration |
|----------------|--|
| 0x00 | Turn off the light sensing auxiliary control function, and the OUT pin output is not affected by light sensing |
| 0x01 | Enable the light sensing auxiliary control function, and when the detected light sensing value is less than the set threshold, the auxiliary control conditions are met The second byte is the light sensing threshold to be set (range 0x00~0xFF) |
| 0x02 | Enable the light sensing auxiliary control function, and when the light sensing detection value is greater than the set threshold, the auxiliary control conditions are met; The second byte is the light sensing threshold to be set (range 0x00~0xFF) |

The factory default value is 0x00, which means the light sensing auxiliary control function is turned off

| The second byte | Illustration |
|-----------------|--|
| 0x00 ~ 0xFF | The light sensitivity threshold to be set (range 0-255) defaults to 0x80 |

OUT pin default level configuration

| The third byte configuration value | Illustration |
|------------------------------------|--|
| 0x00 | OUT pin defaults to low level, outputs low level when no target is triggered, and outputs high level when there is a target trigger |
| 0x01 | OUT pin defaults to high level, outputs high level when there is no target trigger, and outputs low level when there is a target trigger |

The default value is 0x00, which means the OUT pin defaults to a low level

Sending data:

| | | | | |
|-------------|-------|-------|-------------|-------------|
| FD FC FB FA | 06 00 | AD 00 | 01 60 00 00 | 04 03 02 01 |
|-------------|-------|-------|-------------|-------------|

When the detected light sensitivity value is less than the set threshold, the auxiliary control condition is satisfied; The light sensing threshold is set to 0x060; OUT default level is low level

Radar ACK (success):

| | | | | |
|-------------|-------|-------|-------|-------------|
| FD FC FB FA | 04 00 | AD 01 | 00 00 | 04 03 02 01 |
|-------------|-------|-------|-------|-------------|

2.2.19 Query auxiliary control function configuration

Query the current auxiliary control configuration value of the module

Command word: 0x00AE

Command value: None

Return value: 2-byte ACK status (0 successful, 1 failed)+4-byte configuration value

The definition of configuration values is the same as the command values for auxiliary control function settings in Table 9

Sending data:

| | | | |
|-------------|-------|-------|-------------|
| FD FC FB FA | 02 00 | AE 00 | 04 03 02 01 |
|-------------|-------|-------|-------------|

Radar ACK (success):

| | | | | | |
|-------------|-------|-------|-------|-------------|-------------|
| FD FC FB FA | 08 00 | AE 01 | 00 00 | 01 60 01 00 | 04 03 02 01 |
|-------------|-------|-------|-------|-------------|-------------|

Indicates that the auxiliary control condition is met when the detected light sensitivity value is less than the set threshold; The light sensing threshold is set to 0x060; OUT default level is high level

2.2.20 Start performing background noise detection and automatic sensitivity configuration

After receiving this command, the module will enter the bottom noise detection mode and start detection after 10 seconds. It is required that everyone leave the detection range of the module within 10 seconds and ensure that there is no one within the detection range of the module during the detection process. The module will

automatically calculate and record the energy value on each distance door under unmanned conditions, which is the background noise value. After the detection is completed, the sensitivity value of each distance door will be automatically configured based on the detected background noise value.

During the process of performing bottom noise detection, there will be corresponding outputs for the target state values in the reported data frames to indicate the current state. Please refer to Table 14 for details on target state values.

Command word: 0x000B

Command value: Two byte detection duration value, in seconds

Return value: 2-byte ACK status (0 successful, 1 failed)

Sending data:

| | | | | |
|-------------|-------|-------|-------|-------------|
| FD FC FB FA | 04 00 | 0B 00 | 0A 00 | 04 03 02 01 |
|-------------|-------|-------|-------|-------------|

Radar ACK (success):

| | | | | |
|-------------|-------|-------|-------|-------------|
| FD FC FB FA | 04 00 | 0B 01 | 00 00 | 04 03 02 01 |
|-------------|-------|-------|-------|-------------|

2.2.21 Querying the Execution Status of Bottom Noise Detection

This command is used to query the status value of background noise detection

Command word: 0x001B

Command value: None

Return value: 2-byte ACK status (0 successful, 1 failed)+2-byte status value

Status value: 0x0000 not in progress, 0x0001 in progress, 0x0002 detection completed

Sending data:

| | | | |
|-------------|-------|-------|-------------|
| FD FC FB FA | 02 00 | 1B 00 | 04 03 02 01 |
|-------------|-------|-------|-------------|

Radar ACK (success):

| | | | | | |
|-------------|-------|-------|-------|-------|-------------|
| FD FC FB FA | 06 00 | 1B 01 | 00 00 | 01 00 | 04 03 02 01 |
|-------------|-------|-------|-------|-------|-------------|

2.3 Radar data output protocol

LD2410C outputs the radar detection result through serial port, the default output is basic target information, including target status, motion energy value, stationary energy value, motion distance, stationary distance and other information. If the radar is

configured as engineering mode, the radar will additionally output each distance gate energy value (motion & stationary). Radar data is output in the prescribed frame format.

2.3.1 Reported data frame format

The format of the radar uplink message frames defined by the protocol is shown in 10 and 11. The definition of the report data type values in normal operation mode and engineering mode are shown in Table 12.

Table 9 Reported data frame format

| Frame header | Length of data in the frame | Intra-frame data | End of frame |
|--------------|-----------------------------|------------------|--------------|
| F4 F3 F2 F1 | 2 bytes | See Table 11 | F8 F7 F6 F5 |

Table 10 Intra-frame data frame format

| Data type | Head | Target data | Tail | Calibration |
|-----------------------|------|------------------------|------|-------------|
| 1 byte (See Table 12) | 0xAA | See Table 13, Table 15 | 0x55 | 0x00 |

Table 11 Data type description

| Data type value | Description |
|-----------------|-------------------------------|
| 0x01 | Engineering mode data |
| 0x02 | Target basic information data |

2.3.2 Target data composition

The content of the target data reported by the radar will change depending on the operating mode of the radar. In normal operation mode, the radar outputs the basic information data of the target by default; when configured to engineering mode, the radar adds each distance gate energy value information after the basic information data of the target. Therefore, the basic information of the target will always be output in the radar report data, while the distance gate energy value information needs to be enabled by command to be output.

The composition of the target data reported by the radar in normal operation mode is shown in Table 11, and the definition of the target state values is shown in Table 12. The composition of the target data frame in engineering mode is shown in Table 13, with additional data added to the data reported in normal operation mode.

Table 12 Target basic information data composition

| Target Status | Movement target distance (cm) | Exercise target energy value | Distance to stationary target (cm) | Stationary target energy value | Detection distance (cm) |
|-----------------------|-------------------------------|------------------------------|------------------------------------|--------------------------------|-------------------------|
| 1 byte (See Table 12) | 2 bytes | 1 byte | 2 bytes | 1 byte | 2 bytes |

Table 13 Target state value description

| Target state value | Description |
|--------------------|---|
| 0x00 | No target |
| 0x01 | Campaign target |
| 0x02 | Stationary target |
| 0x03 | Campaign & Stationary target |
| 0x04 | Under background noise detection, only valid when performing background noise detection function |
| 0x05 | Bottom noise detection successful, only valid when performing the bottom noise detection function |
| 0x06 | Bottom noise detection failed, only valid when performing the bottom noise detection function |

Table 14 Engineering model target data composition

Add the following data after the target basic information data in Table 11

| | | | | | | | | | |
|-----|----------------------------------|---------------------------------|---------------------------------------|-----|---------------------------------------|---|-----|---|---|
| ... | Maximum movement distance door N | Maximum resting distance door N | Movement distance gate 0 energy value | ... | Movement distance gate N energy value | Stationary distance gate 0 energy value | ... | Stationary distance gate N energy value | Retain data, store additional information |
| ... | 1 byte | 1 byte | 1 byte | ... | 1 byte | 1 byte | ... | 1 byte | M byte |

Example of reported data:

Data reported in normal operating mode:

| Frame header | Length of data in frame | Intra-frame data | End of frame |
|--------------|-------------------------|--|--------------|
| F4 F3 F2 F1 | 0D 00 | 02 AA 02 51 00 00 00 00 3B 00 00 55 00 | F8 F7 F6 F5 |

Data reported in engineering mode:

| Frame header | Length of data in frame | Intra-frame data | End of frame |
|--------------|-------------------------|--|--------------|
| F4 F3 F2 F1 | 23 00 | 01 AA 03 1E 00 3C 00 00 39 00 00 08 08 3C 22 05 03 03 04 03 06 05 00 00 39 10 13 06 06 08 04 03 05 55 00 | F8 F7 F6 F5 |

Example analysis:

F4 F3 F2 F1 Frame Head 23 00 Frame Data Length 01 Engineering Mode

AA frame data header 03 target state value 1E 00 moving target distance 3C moving target energy value

00 00 Static target distance 39 Static target energy value 00 00 Detection distance

08 08 Maximum Motion Distance Door Maximum Static Distance Door

3C 22 05 03 03 04 06 05 Motion distance door energy value (9)

00 00 39 10 13 06 08 04 Static distance door energy values (9)

60 photosensitive 01 out status 55 00 tail verification

F8 F7 F6 F5 End of frame

2.4 Radar command configuration method

2.4.1 Radar command configuration steps

The process of executing a configuration command by LD2410C radar consists of two parts: the upper computer "sends the command" and the radar "replies to the command ACK". If the radar does not reply with ACK or fails to reply with ACK, it means the radar fails to execute the configuration command.

As mentioned earlier, before sending any other commands to the radar, the developer needs to send the "enable configuration" command and then send the configuration command within the specified time. After the commands are configured, the "end configuration" command is sent to inform the radar that the configuration is finished.

For example, if you want to read the radar configuration parameters, first the host computer sends the "enable configuration" command; after receiving a successful radar ACK, then sends the "read parameters" command; after receiving a successful radar ACK, finally sends the "end configuration" command; after receiving successful radar ACK, it indicates that the complete action of reading parameters is finished.

The radar command configuration flow is shown in the following figure.

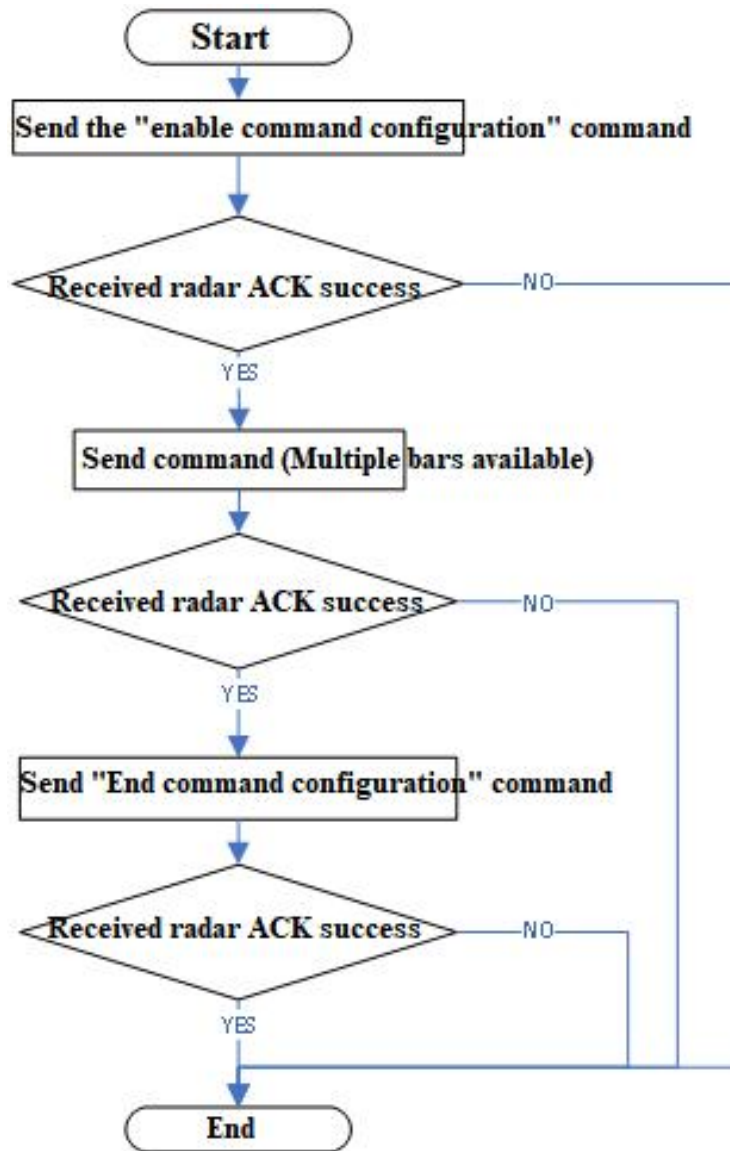

Figure 2 Radar command configuration process

3 Revision records

| Data | version | Modify the content |
|------------|---------|--|
| 2022-6-24 | 1.01 | Initial version |
| 2022-07-01 | 1.02 | Fix some incorrect descriptions, add restart and factory reset commands |
| 2022-07-19 | 1.03 | Correct the length values of some command instances |
| 2022-08-26 | 1.04 | Instructions for configuring commands to increase distance resolution |
| 2022-09-20 | 1.05 | Add protocols for Bluetooth |
| 2023-02-21 | 1.06 | Add instructions for outputting light sensitivity values and commands for setting auxiliary control functions |
| 2024-08-05 | 1.07 | Command instructions for adding background noise detection and sensitivity automatic configuration related functions |
| 2024-11-22 | 1.08 | Modify some instruction reply errors and add engineering mode data parsing |

4 Technical support and contact information



Shenzhen Hi-Link Electronic Co.,Ltd

Email: sales@hlktech.com

Website: www.hlktech.net